

1450 + 615 LOFT BARNDOMINIUM PROJECT



DAVIS & REED HOMES



www.autodesk.com/revit

REVIEW MODE

FRONT ELEVATION



WALL HEIGHTS TBD PER GRADE/FROST PROTECTION

REAR ELEVATION

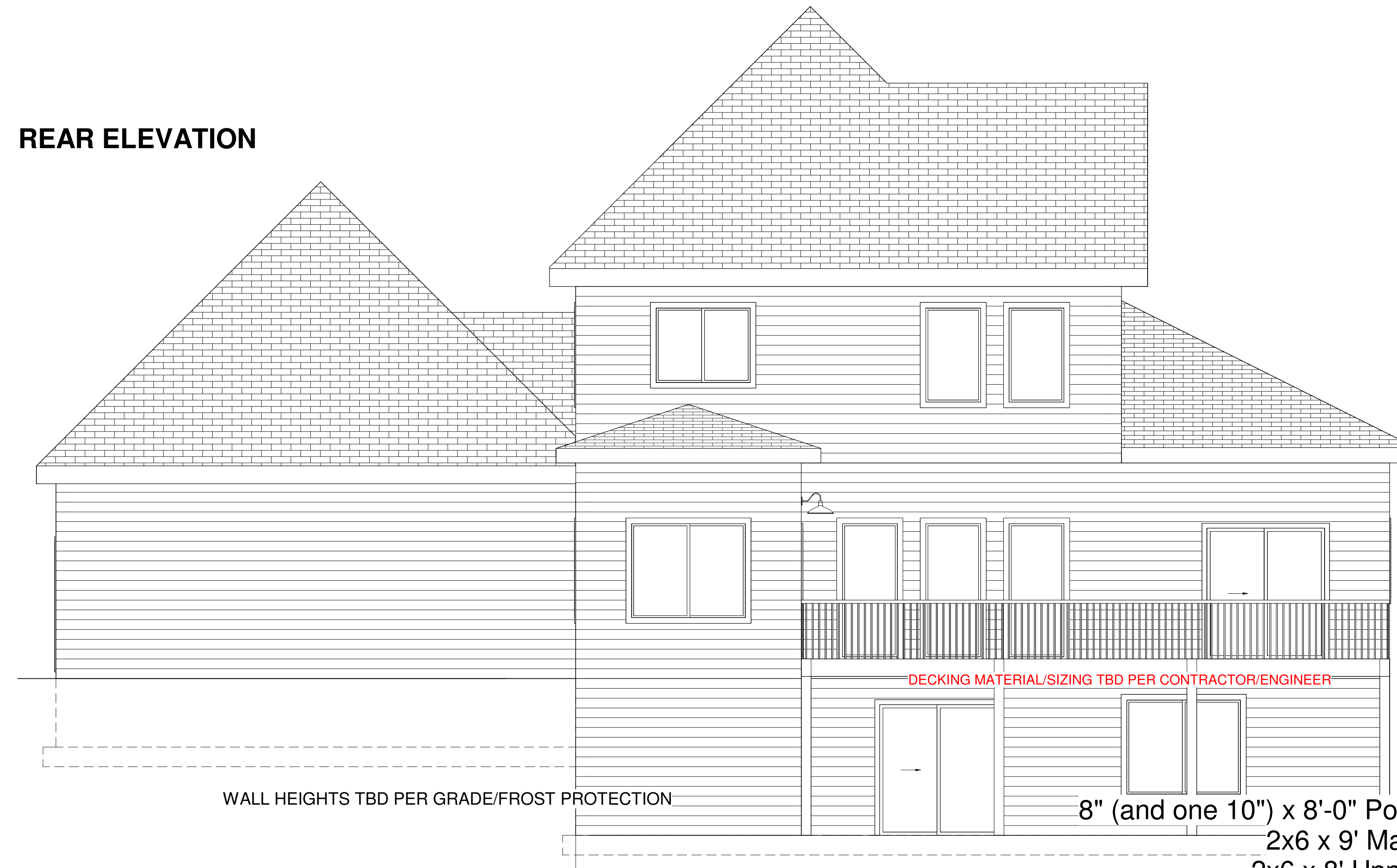

WALL HEIGHTS TBD PER GRADE/FROST PROTECTION

8" (and one 10") x 8'-0" Poured Foundation Walls
2x6 x 9' Main Floor Exterior Walls
2x6 x 8' Upper Floor Exterior Walls

Typical Deck Details

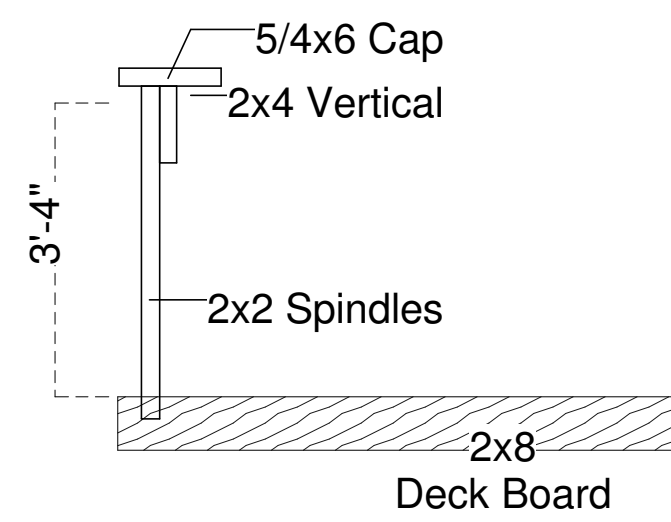

Handrail Section

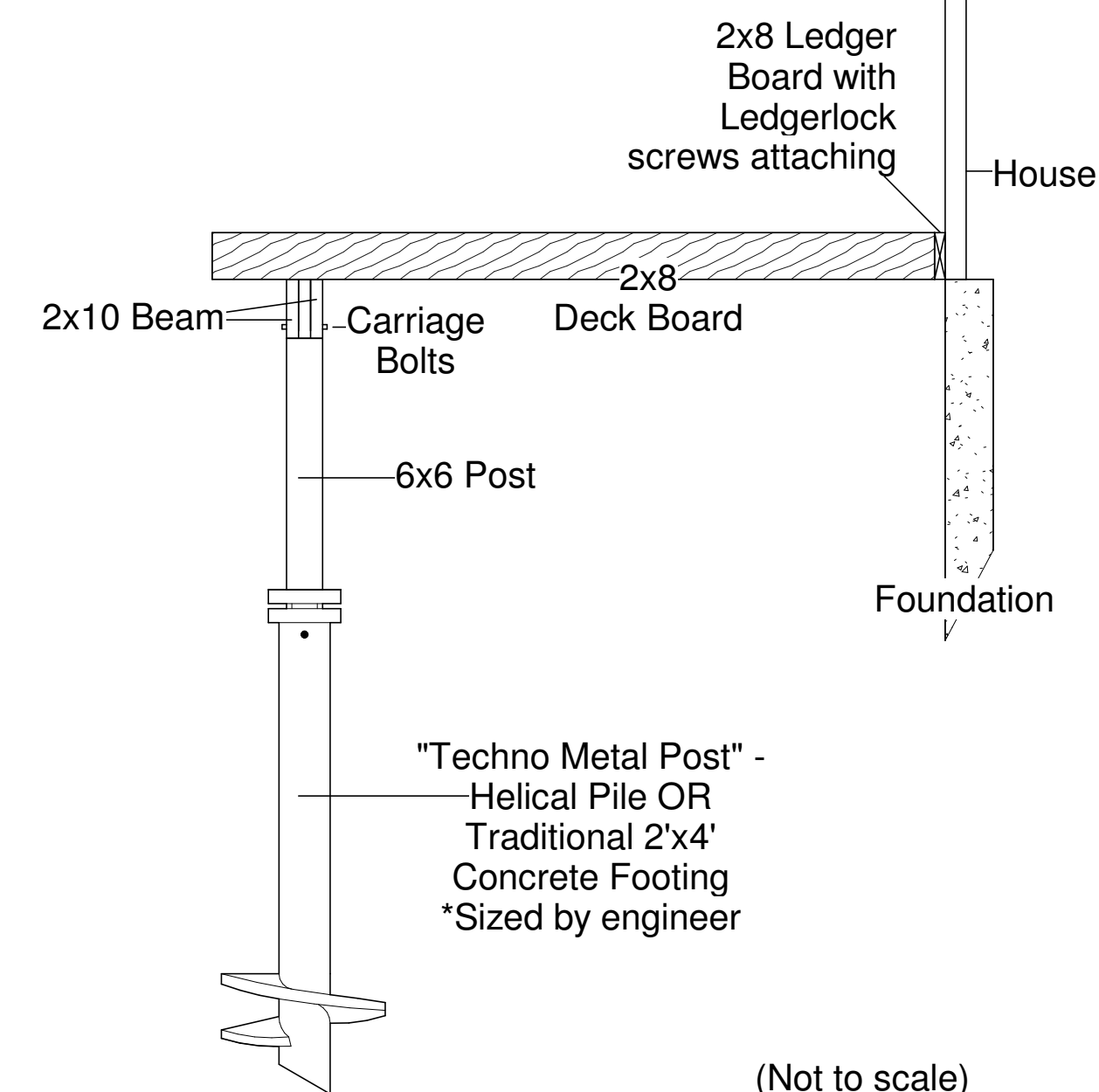

(Not to scale)

Structure Section

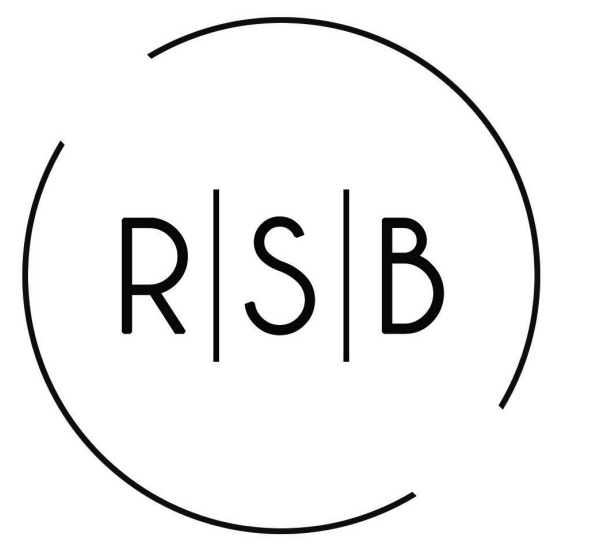

RIGHT SIDE BRAIN
designs

RSB Designs drawings, plans, etc. are the sole property of RSB Designs and may not be copied in whole or part, printed or otherwise disseminated without express written permission of RSB Designs.

Date	Description
06/28/23	REVIEW MODE

Square Footages	
Main Level House:	Approx. 1450 SF Finished
Loft Area:	Approx. 615 SF Finished
Basement:	Approx. 1323 SF Finished
Garage:	Approx. 1026 SF

**RSB Designs
Davis & Reed
Elevations**

Project Address/Name	Custom
Date	REVIEW 06/28/2023
Drawn by	Brit Borcharding
Checked by	Checker
Scale	A100 As indicated

This floor plan is for informational purposes only. The details including but not limited to sizes and options are subject to change and should be independently verified by the buyer with the General Contractor.

Right Side Brain Designs
2405 6th Ave SW, Altoona
(515) 890-9951
www.RSBDesigns.com

1450 + 615 LOFT BARNDOMINIUM PROJECT

REVIEW MODE



www.autodesk.com/revit

Lower Level:

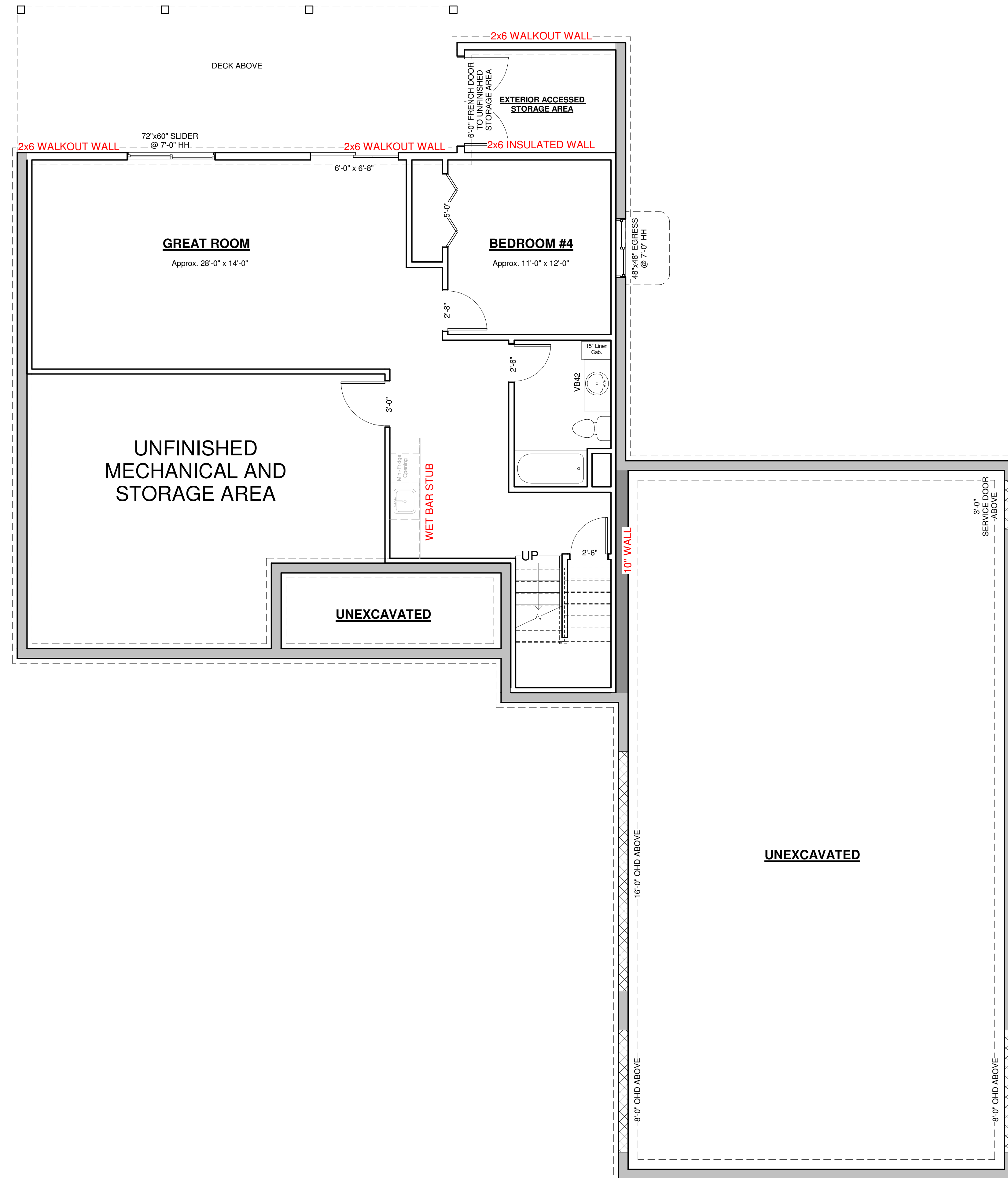

RIGHT SIDE BRAIN
designs

RSB Designs drawings, plans, etc. are the sole property of RSB Designs and may not be copied in whole or part, printed or otherwise disseminated without express written permission of RSB Designs.

Date	Description
06/28/23	REVIEW MODE

Square Footages	
Main Level House:	Approx. 1450 SF Finished
Loft Area:	Approx. 615 SF Finished
Basement:	Approx. 1323 SF Finished
Garage:	Approx. 1026 SF

RSB Designs
Davis & Reed
Lower Level

Project Address/Name	Custom
Date	REVIEW 06/28/2023
Drawn by	Brit Borcharding
Checked by	Checker

A101

Scale	1/4" = 1'-0"
-------	--------------

This floor plan is for informational purposes only. The details including but not limited to sizes and options are subject to change and should be independently verified by the buyer with the General Contractor.

Right Side Brain Designs
2405 6th Ave SW, Altoona
(515) 890-9951
www.RSBDesigns.com

1450 + 615 LOFT BARNDOMINIUM PROJECT

REVIEW MODE



www.autodesk.com/revit



RIGHT SIDE BRAIN
designs

RSB Designs drawings, plans, etc. are the sole property of RSB Designs and may not be copied in whole or part, printed or otherwise disseminated without express written permission of RSB Designs.

Main Level:

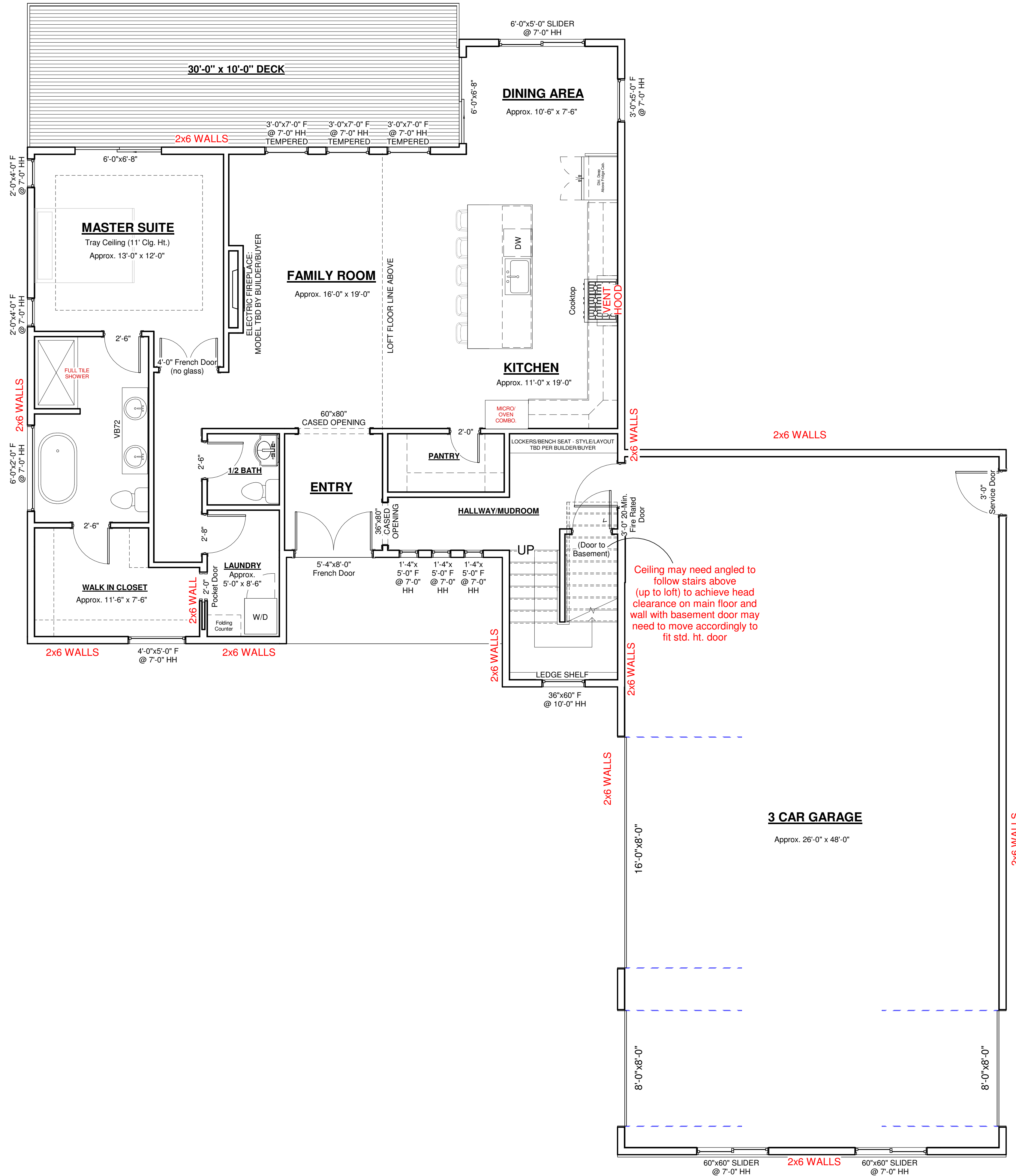

Date	Description
06/28/23	REVIEW MODE

Square Footages	
Main Level House:	Approx. 1450 SF Finished
Loft Area:	Approx. 615 SF Finished
Basement:	Approx. 1323 SF Finished
Garage:	Approx. 1026 SF

RSB Designs Davis & Reed Main Level	
Project Address/Name	Custom
Date	REVIEW 06/28/2023
Drawn by	Brit Borcharding
Checked by	-
A102	
Scale	1/4" = 1'-0"

This floor plan is for informational purposes only. The details including but not limited to sizes and options are subject to change and should be independently verified by the buyer with the General Contractor.

Right Side Brain Designs
2405 6th Ave SW, Altoona
(515) 890-9951
www.RSBDesigns.com

1450 + 615 LOFT BARNDOMINIUM PROJECT

REVIEW MODE



www.autodesk.com/revit

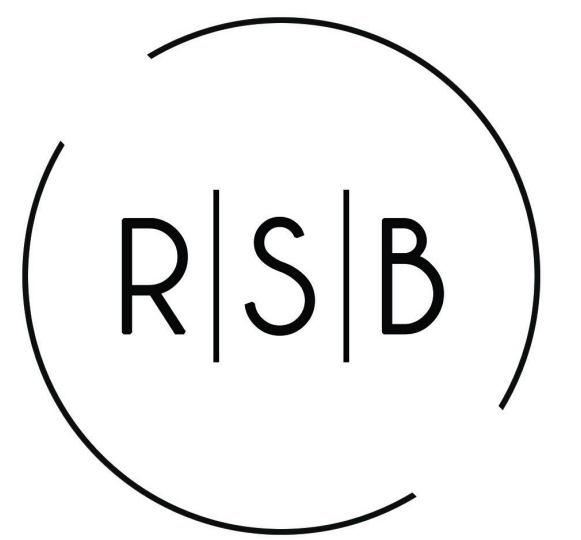

RIGHT SIDE BRAIN
designs

RSB Designs
drawings, plans, etc.
are the sole property
of RSB Designs and
may not be copied in
whole or part, printed
or otherwise
disseminated without
express written
permission of RSB
Designs.

Date	Description
06/28/23	REVIEW MODE

Square Footages	
Main Level House:	Approx. 1450 SF Finished
Loft Area:	Approx. 615 SF Finished
Basement:	Approx. 1323 SF Finished
Garage:	Approx. 1026 SF

RSB Designs Davis & Reed Upper Loft Area

Project Address/Name	Custom
Date	REVIEW 06/28/2023
Drawn by	Brit Borcharding
Checked by	Checker
	A103
Scale	1/4" = 1'-0"

This floor plan is for
informational purposes only.
The details including but not
limited to sizes and options
are subject to change and
should be independently
verified by the buyer with the
General Contractor.

Right Side Brain Designs
2405 6th Ave SW, Altoona
(515) 890-9951
www.RSBDesigns.com

Upper Level:

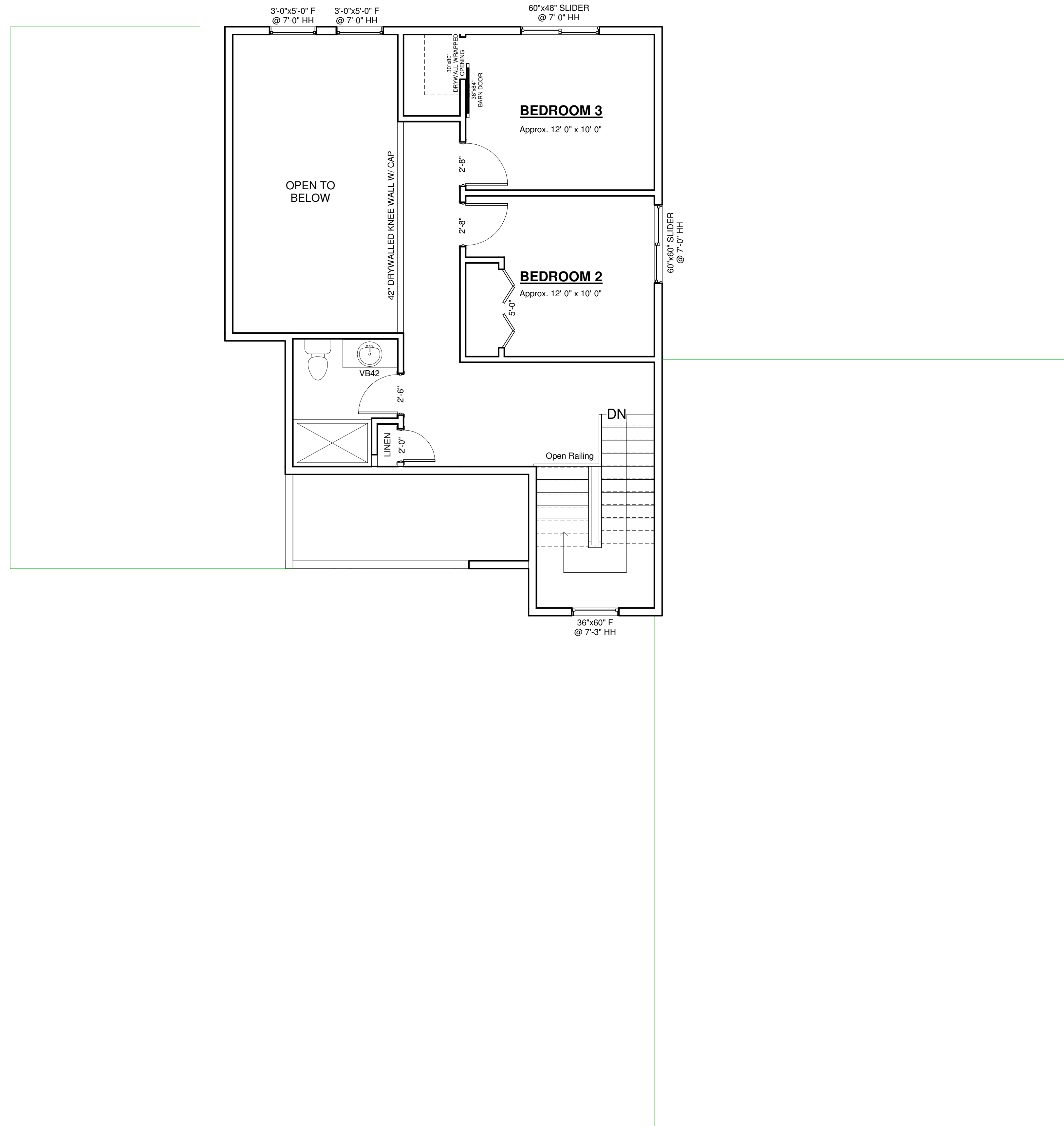

Roof Layout:

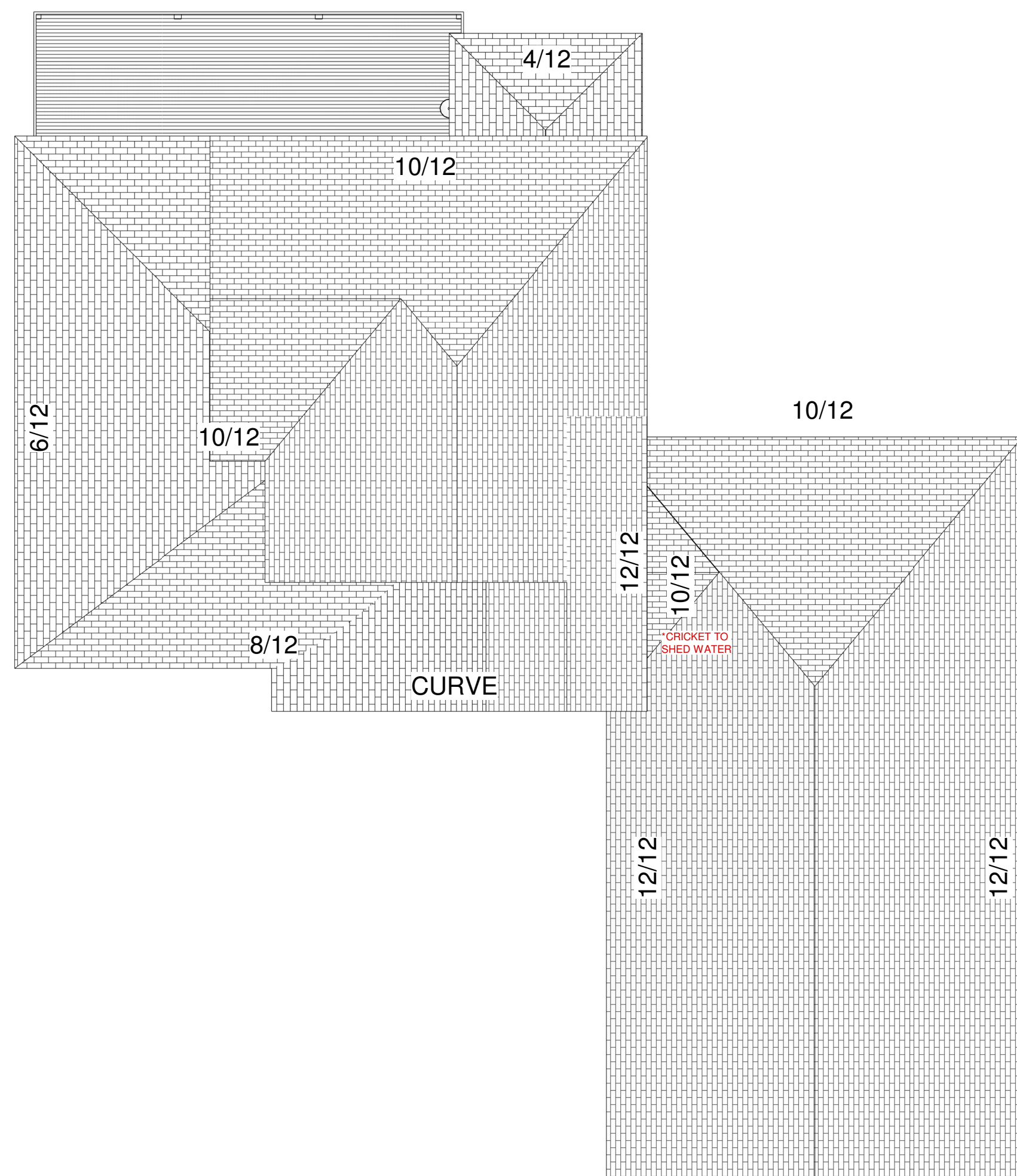

1450 + 615 LOFT BARNDOMINIUM PROJECT

REVIEW MODE



www.autodesk.com/revit



RIGHT SIDE BRAIN
designs

RSB Designs drawings, plans, etc. are the sole property of RSB Designs and may not be copied in whole or part, printed or otherwise disseminated without express written permission of RSB Designs.

Date	Description
06/28/23	REVIEW MODE

Square Footages	
Main Level House:	Approx. 1450 SF Finished
Loft Area:	Approx. 615 SF Finished
Basement:	Approx. 1323 SF Finished
Garage:	Approx. 1026 SF

RSB Designs Davis & Reed Elevations 2

Project Address/Name	Custom
Date	REVIEW 06/28/2023
Drawn by	Brit Borcharding
Checked by	Checker
	A104
Scale	As indicated

This floor plan is for informational purposes only. The details including but not limited to sizes and options are subject to change and should be independently verified by the buyer with the General Contractor.

Right Side Brain Designs
2405 6th Ave SW, Altoona
(515) 890-9951
www.RSBDesigns.com

RIGHT ELEVATION

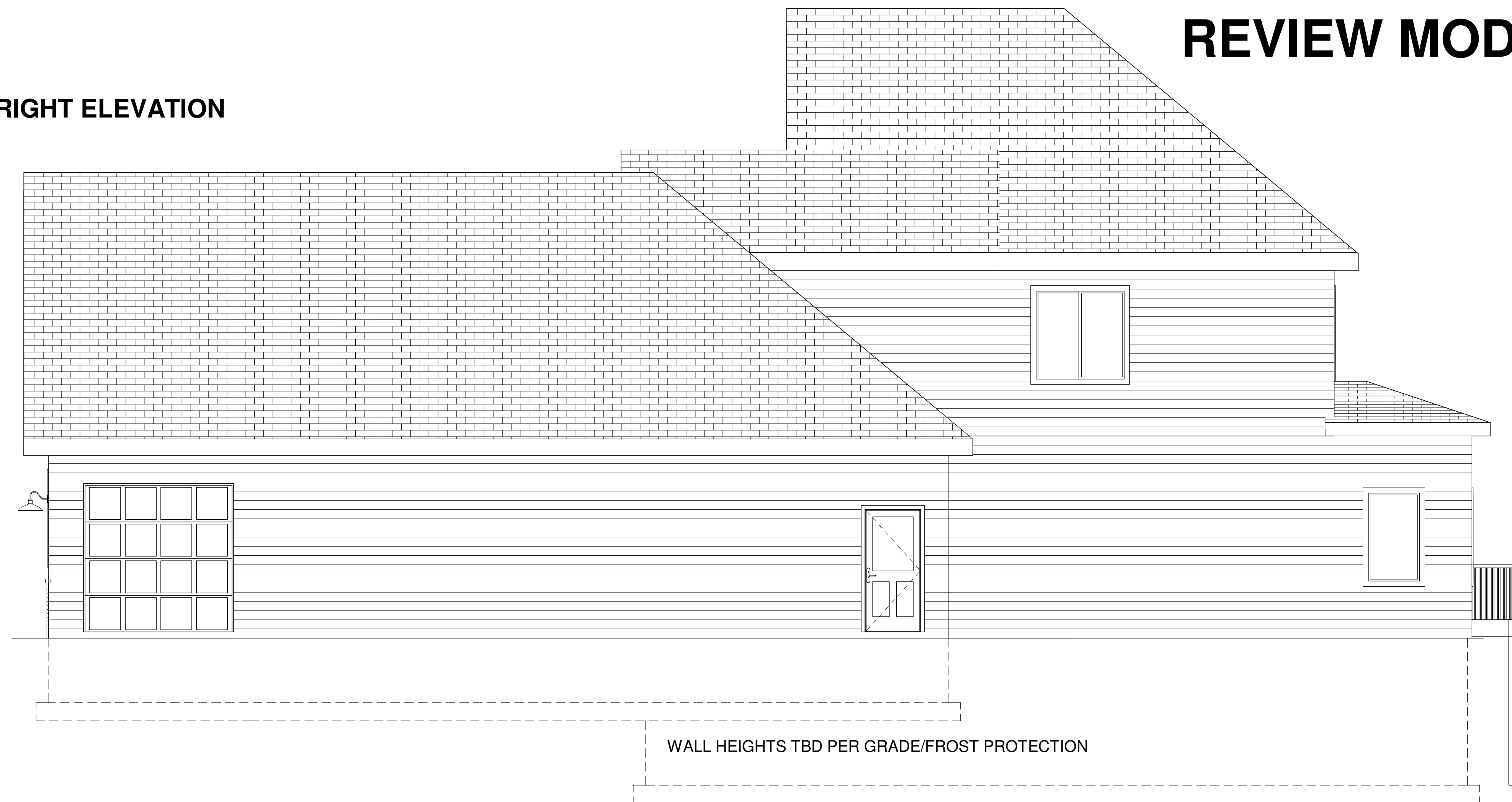

LEFT ELEVATION



TYPICAL EXTERIOR WALL SECTION

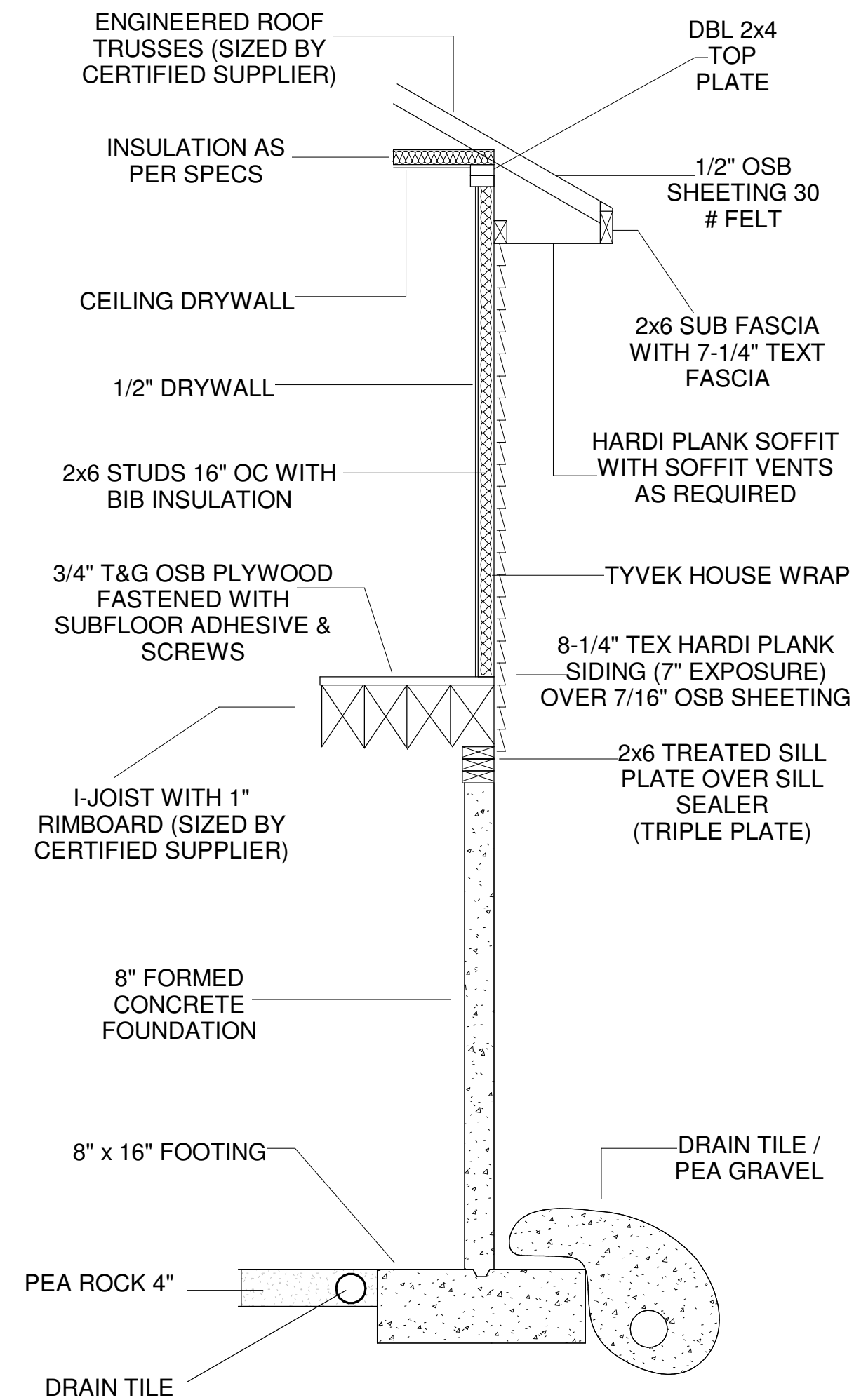

(NOT TO SCALE)

TYPICAL STAIR DETAILS

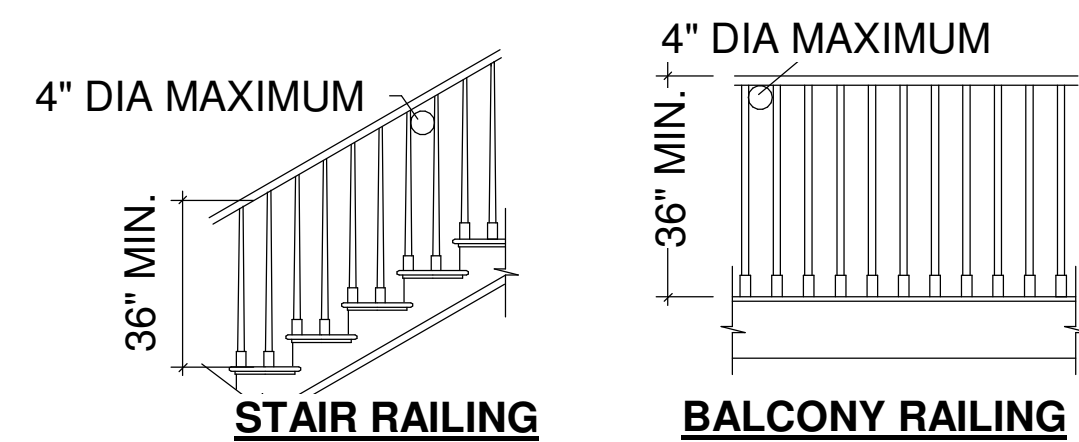
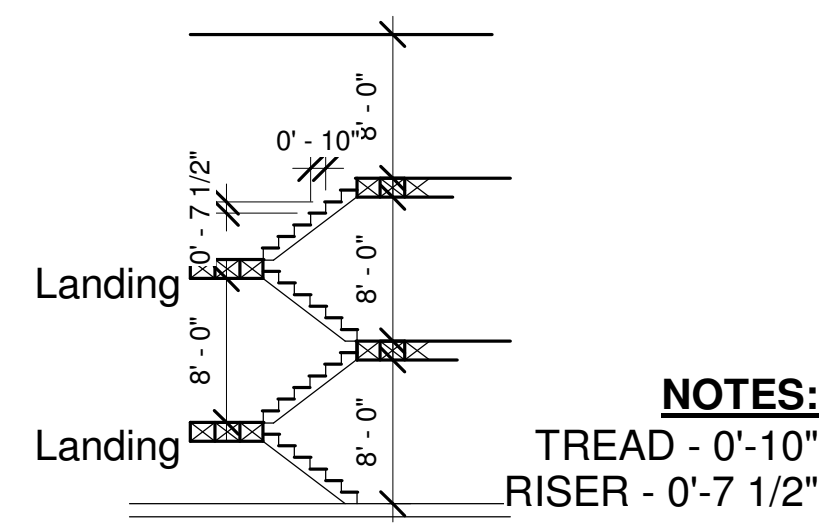

STAIR/BALUSTER STYLES ARE DIAGRAMATIC ONLY - CONTRACTOR TO COORDINATE STYLES WITH OWNER/ FINISHES

ALL HANDRAILS SHALL BE CONTINUOUS THE FULL LENGTH OF THE STAIRS. HANDGRIP PORTION OF ALL HANDRAILS SHALL NOT BE LESS THAN 1-1/4" NOR MORE THAN 2" IN CROSS SECTIONAL DIMENSION, OR THE SHAPE SHALL PROVIDED AN EQUIVALENT GRIPPING SURFACE

NOT LESS THAN 36" IN HEIGHT WITH PATTERN / SPACING SUCH THAT A SPHERE 4" IN DIA. CANNOT PASS THROUGH

(NOT TO SCALE)